

Assembly Instructions

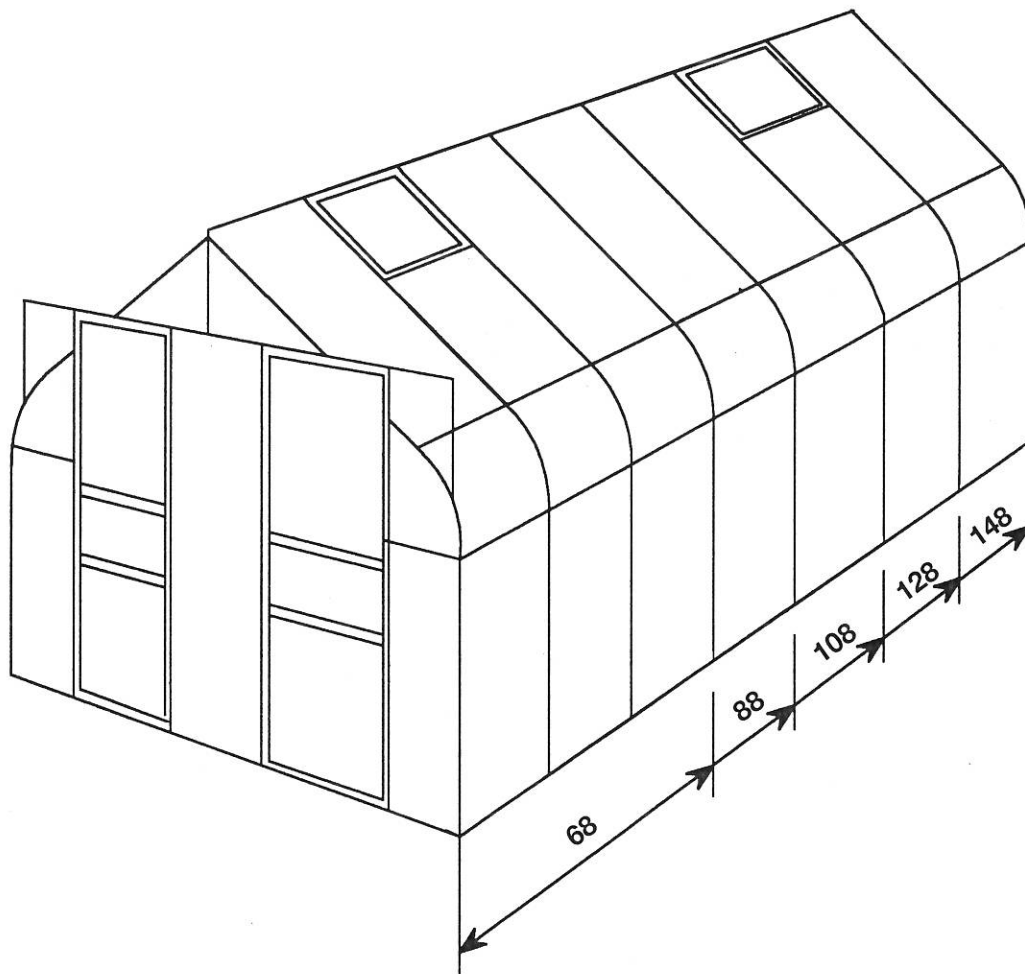









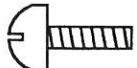

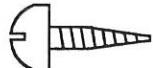
Double Door Curved





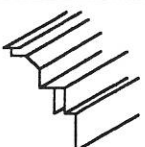

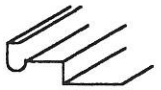
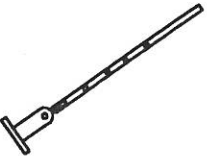

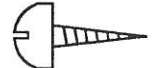



Models
68, 88, 108, 128, 148

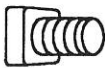

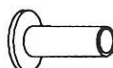
Item No.	Section	Page Ref	Size mm	Quantity Per				
				68	88	108	128	148
13055		1	2804	1	1	1	1	1
13056		1	2804	1	1	1	1	1
13062		2	2804	1	1	1	1	1
13063		2	2804	1	1	1	1	1
13057		1	2484	1	1	1	1	1
01749			1743	1	1	1	1	1
01750		1	1743	1	1	1	1	1
13060			2135	1	1	1	1	1
01756		1	1242	2	2	2	2	2
		2		2	2	2	2	
13058		1	2469	1	1	1	1	1
13059		1	1257	1	1	1	1	1
13061		1		1	1	1	1	1
		2		1	1	1	1	1
13064		2	2484	1	1	1	1	1
01751		2	1725	1	1	1	1	1
01752				1	1	1	1	1
13065		2	608	1	1	1	1	1
13089				1	1	1	1	1
13066		2	410	1	1	1	1	1
13067		2	1252	1	1	1	1	1
13068		2	2502	1	1	1	1	1
01761		2	487	2	2	2	2	2
12223		2	32	1	1	1	1	1
		6		1	1	1	1	1
8698		2	15	2	2	2	2	2
1747		2	M6x40	3	3	3	3	3
		6						
681		2	M6	2	2	2	2	2
		6						

Item No.	Section	Page Ref	Size mm	Quantity Per				
				68	88	108	128	148
1755		3	1250	4	4	4	4	4
1743		3	1862	2				
1737		3	2484		2			
13086		3	3106			2		
13087		3	3728				2	
13088		3	4350					2
13071		3	1862	4				
13072		3	2484		4			
13073		3	3106			2		
13074		3	3728				2	
13075		3	4350					2
13076		3	3106			2		
13077		3	3728				2	
13078		3	4350					2
13081			3	1862	1			
13082	3		2484		1			
13083	3		3106			1		
13084	3		3728				1	
13085	3		4350					1
13069		4	2792	4	6	8	10	12
13070		4	838	2	3	4	5	6
13079		5	1215	4	4	4	4	4
8615		5	642	1	2	2	4	4
1753		6	1684	2	2	2	2	2
13090		6	1684	1	1	1	1	1
13091		6	1684	1	1	1	1	1
8610		6	626	2	2	2	2	2
1726		6	626	3	3	3	3	3
13503		6	626	1	1	1	1	1
1727		6	626	2	2	2	2	2
8611		6	618	2	2	2	2	2
13504		6	100	1	1	1	1	1

Item No.	Section	Page Ref	Size mm	Quantity Per				
				68	88	108	128	148
1745		6	M4x16	4	4	4	4	4
699		6	M4	4	4	4	4	4
401		6	No6x19	32	32	32	32	32
799		6		4	4	4	4	4
1645		6	M4	4	4	4	4	4
333		6	1684	2	2	2	2	2
783		6		2	2	2	2	2
12224		6	35	4	4	4	4	4
1738		7	602	1	2	2	4	4
1730		7	522	2	4	4	8	8
8632		7	602	1	2	2	4	4
8617		7	250	1	2	2	4	4
8616		7		2	4	4	8	8
8588		7		1	2	2	4	4
402		7	No6x6	6	12	12	24	24

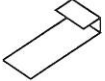
Item No.	Section	Page Ref	Size mm	Quantity Per				
				68	88	108	128	148
12467		8A	610	10	10	10	10	10
710		8	610	12	16	20	24	28
411		8	61000 74000 86000 98000 110000	1	1	1	1	1
697			M6	105	113	127	143	153
400			M6x10	105	113	127	143	153
453		8		286	338	394	442	498
13500		6		1	1	1	1	1
13501		6		1	1	1	1	1
13502		6		1	1	1	1	1
12270		6		1	1	1	1	1
13092		6	25	1	1	1	1	1
458		8B		42	50	56	62	70
135		8B		8	8	8	8	8

A

1

2

3

4

5

6

7

8

SAFETY WARNING

- Always** wear protective glasses, shoes, gloves and headgear when handling glass - sharp edges can cause injury.
- Broken glass is a safety hazard. Clean up immediately - dispose of with care.
- Any difficulty in fitting glass, contact our customer service department for advice - **do not use force**.

Site Selection - Important

Choose a sunny spot for your greenhouse, with as much protection from the wind as possible. In strong winds, close all vents and doors. In the event of heavy snowfall, clear the roof of the building or take suitable measures to support the roof. Observe all building regulations.

Tools Required

Screwdrivers (Normal and Crosshead).
10mm AF spanner or wrench.

Assembly - Important

Before starting the assembly, check the parts against the parts list. Remove packs from box in order to identify parts.

It is important that the open packs do not get mixed. If anything is missing, please contact our Customer Service Department using the form included at the back of these instructions.

Maintenance

To keep your greenhouse clean, wash thoroughly with

mild detergent solution. The glass may be cleaned with any cleaning solution that does not adversely affect the aluminium frame or the glazing clips. Ensure that the upper and lower Door Tracks are regularly cleaned to prevent an accumulation of debris.

Notes

Retain these instructions for future use.

We recommend that you include your greenhouse in your house insurance.

A Base

Ensure base is square and level. A galvanised steel prefabricated base is available from stockists for all models (on very exposed sites, drill sills and steel base and secure with nuts and bolts).

Should you wish to build a brick or concrete base follow the dimensions given in section A. Fix timber battens (29 x 18mm) as shown and drill through sill members in the centre of each bay (leaving adequate room to glaze) and fix using No. 12 x 50mm screws and plugs.

N.B. All illustrations are viewed from the inside. Except those marked XXX.

1 Plain Gable End

- Lay the parts onto the ground and bolt together loosely, remembering to slide enough bolts into each of the vertical glazing bars to fit cross braces. Ensure that frame is square before tightening bolts.

2 Door Gable End

- Lay out the parts as before and bolt them together loosely, as for the plain gable end. Check squareness before tightening bolts. Fit door track support (13067) to gable end bars.
- Fit door track (13068) to door track support (13067) using bolts only in the outer two holes. Ensure that the central hole in (13068) is in line with the central hole in (13067), but do not put a bolt into this position at this stage.
- Use the two outer nuts and bolts to fit brackets (8698) to the door track support, ensuring that the hook locates into the vertical glazing bars [G]. Fit one vertical door track support (1761) to gable end bar [I] and to door track [J].

3 Main Assembly

- Bolt lower eaves brace (13071/13072/13076/13077/13078) and diagonal strut (1755) to one of the assembled gable ends as in [K] using the eaves brace as a temporary support to hold the gable end upright.
- Bolt the side sill bar (1743/1737/13086/13087/13088) to the same gable end as in [L]. The free end of the fitted diagonal strut (1755) can now be loosely bolted to the side sill bar as in [M].
- This should now support the gable end so that it is free standing, allowing you to fit the other gable end to the eaves brace and side sill, with another diagonal brace.

- Repeat the process on the other side of the greenhouse.
- Bolt the ridge (13081/13082/13083/13084/13085) onto the gable end bars as in [J].
- Bolt the remaining (upper) eaves braces (13071/13072/13073/13074/13075) to each gable end.

Note: 13076/13077/13078 are larger and thicker than 13073/13074/13075.

4 Assembly Continued

- Fix the intermediate side glazing bars (13069), remembering to slide sufficient bolts into the slots for fixing to the eaves braces, and for the roof braces (13070).
- Ensure that the upper and lower eaves braces are straight and level. Decide where you wish to fit the roof vent(s) and add additional bolts to the intermediate bars to allow for the roof vent sill(s) (8615).
- You may now fix the roof braces (13070) as in [N].

5 Assembly Continued

- Fit the roof vent sill(s) as in [U] and [V]. Fit loosely at this stage as final positioning will occur when vent(s) is/are fitted.
- The diagonal roof braces (13079) should now be fitted.
- Lift the assembled frame onto the prepared base.
- Now make sure that the frame is absolutely square, with all vertical members plumb. Tighten all bolts, but not so firmly that you damage the aluminium bolts and nuts.**

6 Doors

- Push door sliders (12224) into door bottom rails (1727) at ends. Assemble doors as in main illustration with self tapping screws (401).
- Fit two wheels to each wheelhousing (8611) using M5 nuts and bolts as in [BB] and then fix these sub-assemblies to the top door bars (8610) using M6 nuts and bolts as in [CC].
- Fit weather seals (333) to outer door stiles (1753) as in [DD] and trim to length.
- Slide the door catch (780) as in [EE] to the centre of the vertical stile (13091) and fix in position using two clips (783).
- Assemble the right hand door onto the door track, making sure that the bottom sliders (12224) locate correctly onto the sill, as in diagram [II]. Slide this door to the right hand end of the door track.
- Now fit the door stop (13092) using cheese head screw (1747) from the outside and steel nut (681) on the inside as in [FF].

Fit left hand door to track and then fit second vertical door track support as in [JJ] and [KK].

7 Roof Vents

- Use either 7A or 7B (Note differences in [NN]).
- Bolt both side bars (1730) to roof vent hinge (1738).
- Fit bolts to bottom of side bars.
- Slide glass into side bars as in [MM].
- Fit roof vent bottom bar and fix.
- Check frame is square and tighten nuts.
- Slide top bar of roof vent into ridge bar of building and slide into required position.
- Adjust roof vent sill to suit vent as in [QQ].
- Fit vent stay to vent bottom bar using screws (402).
- Add rubber end cap (8588) to vent stay (8617).
- Fix two vent stay pegs (8616) to vent sill.

8 Glazing

PLEASE NOTE SAFETY WARNING ABOVE

- Use either 8A or 8B
- Fit glazing strips to all glazing bars [SS], and trim to length.
- Glaze sides first, using spring steel clips (453) to hold glass.
- See note Ref Glass Panes 9 and 10 concerning optional louvre.
- Glaze the roof one bay at a time, as follows, gaining access through adjacent bays, using steps or trestles as necessary.
- Add plastic jointing strips (710) to the tops of the vertical panes, and add acrylic sheets (No2) to the jointing strip.
- Part form the acrylic sheet to the curve of the glazing bars, fixing it with spring clips. Note use of clips 453 directly over 710.
- Fit another jointing strip (710) to the top of the acrylic sheet.
- Position the roof sheet No1 or 3 between its glazing bars and link it to the top of the acrylic sheet.
- Finish curving and clipping the acrylic sheet into position and then clip the roof pane into its final position.
- Glazing at gable ends uses jointing strips 12467.

Finishing

- If you wish to seal your greenhouse, apply silicone sealant (not supplied) to all joints.
- Affix "snow clearance" label to a suitable surface to act as a reminder.
- A full range of accessories is available from your stockist to suit this greenhouse. These include additional roof vents and louvre vents for use at low level.

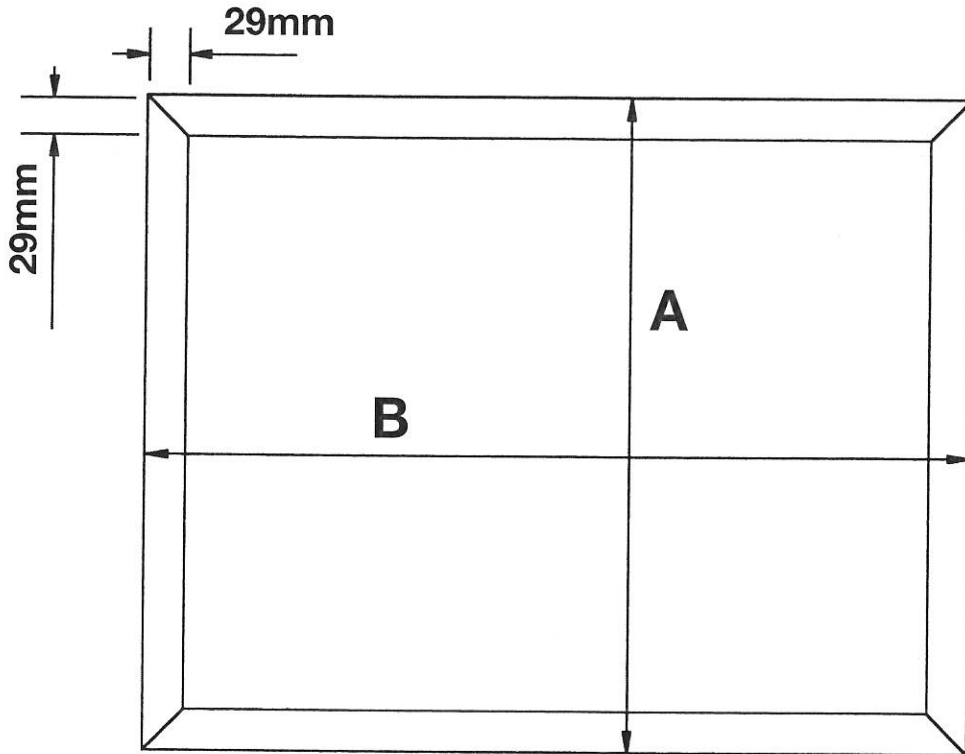
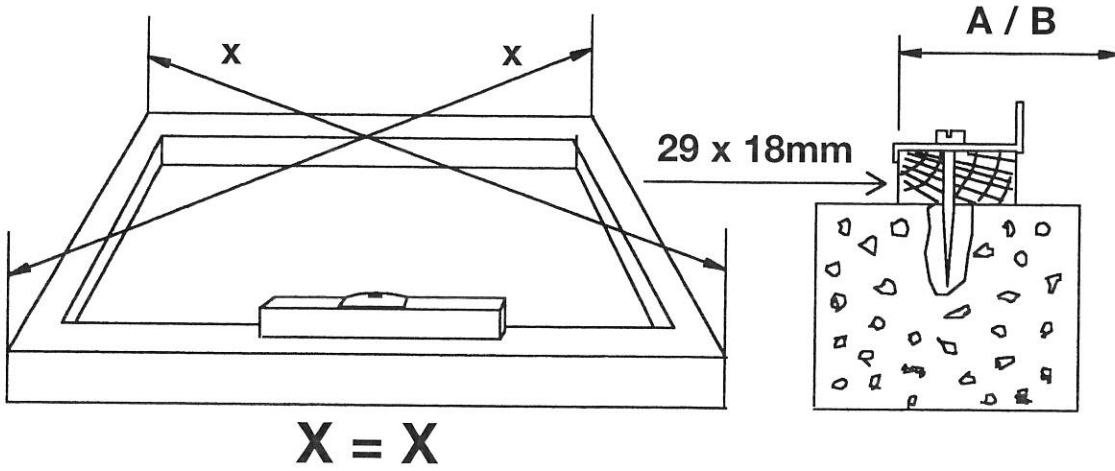

A

	68	88	108	128	148
A	2542	2542	2542	2542	2542
B	1920	2542	3164	3786	4408

ALL DIMENSIONS IN MILLIMETRES

1

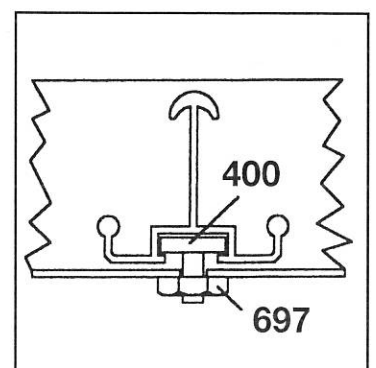
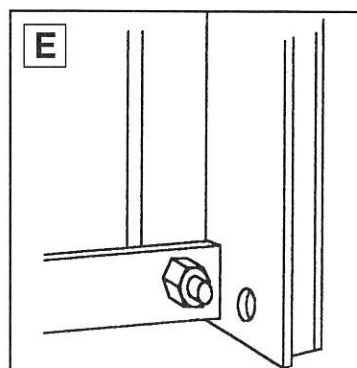
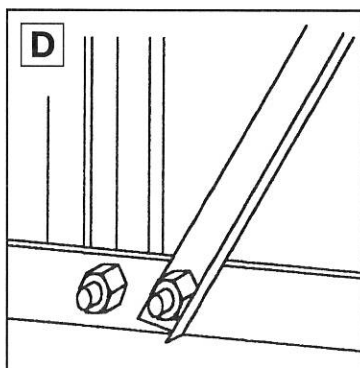
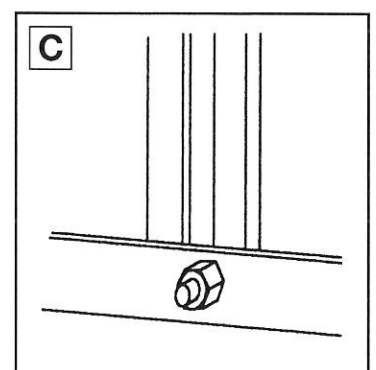
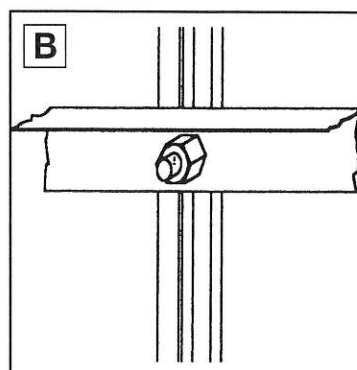
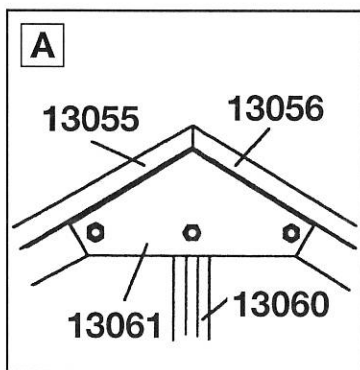
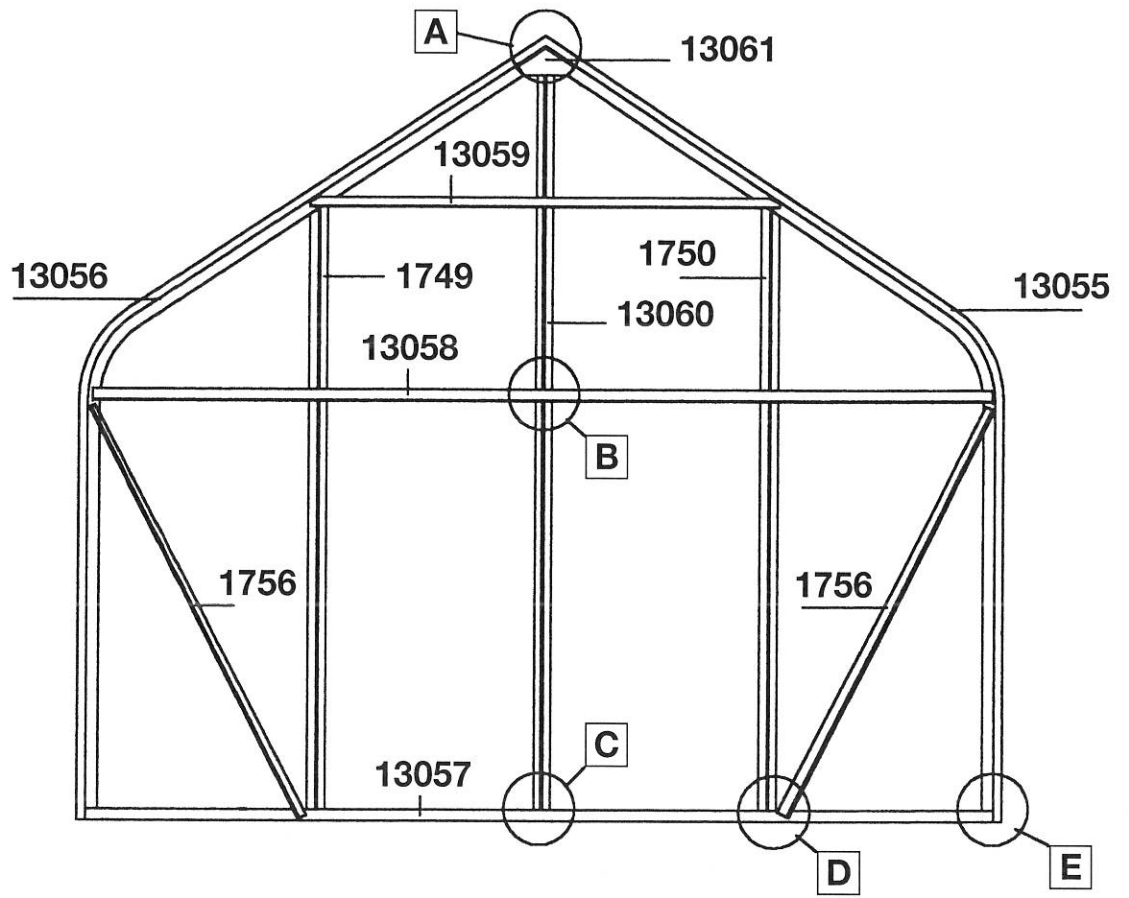

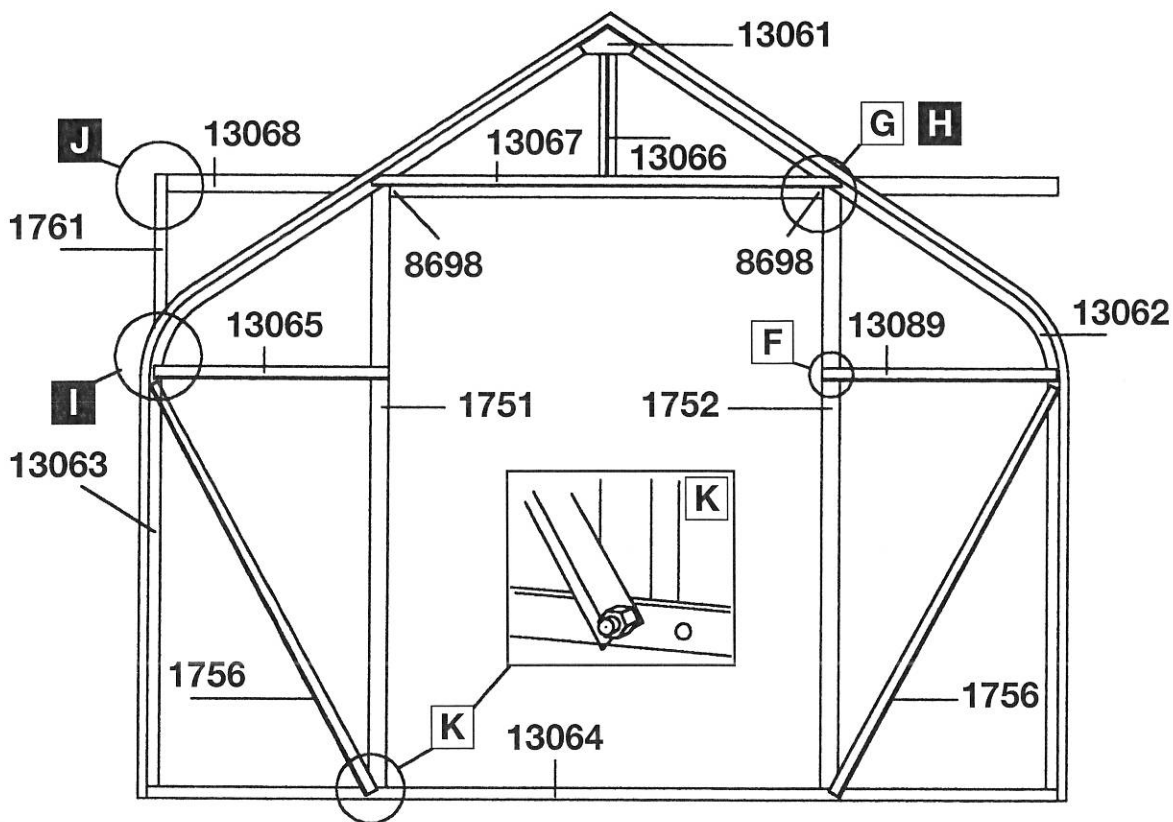

2

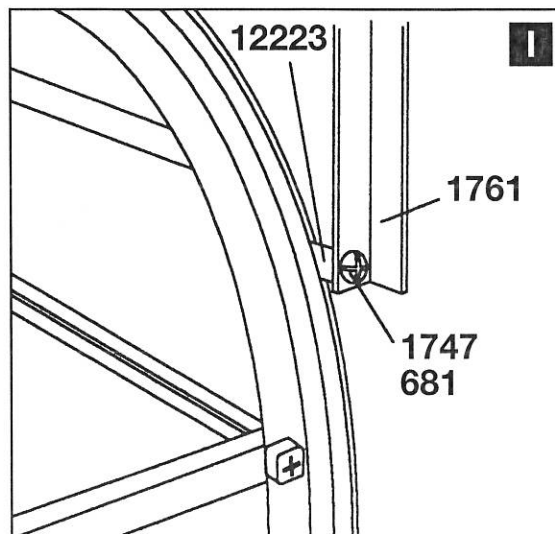
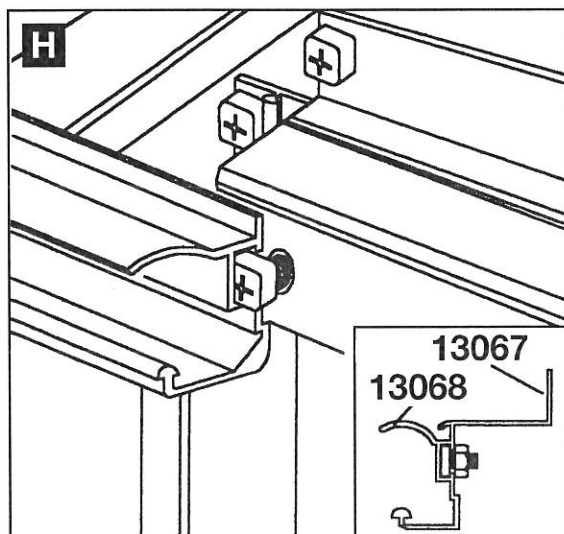
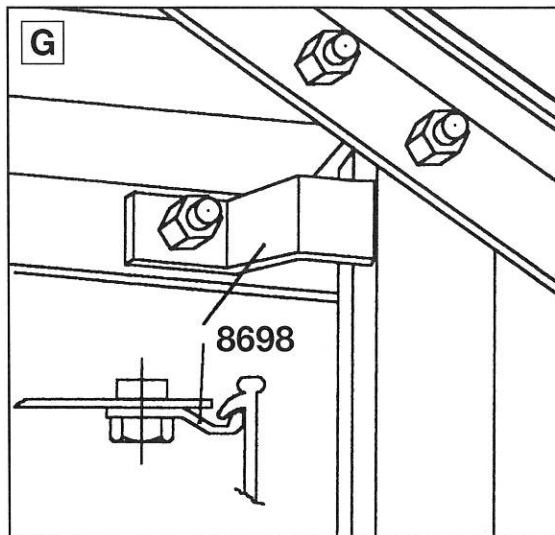
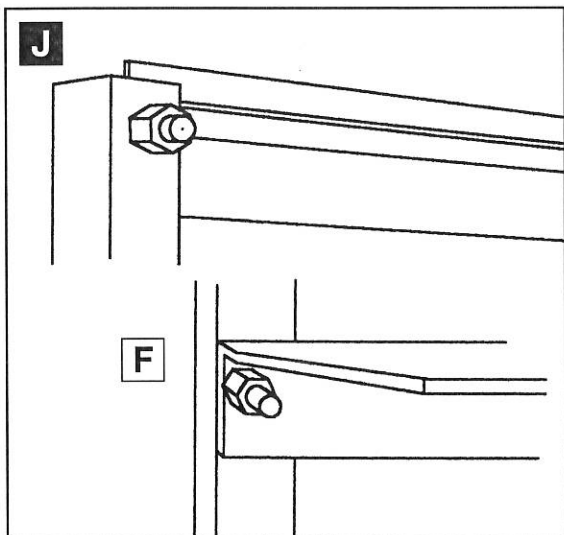

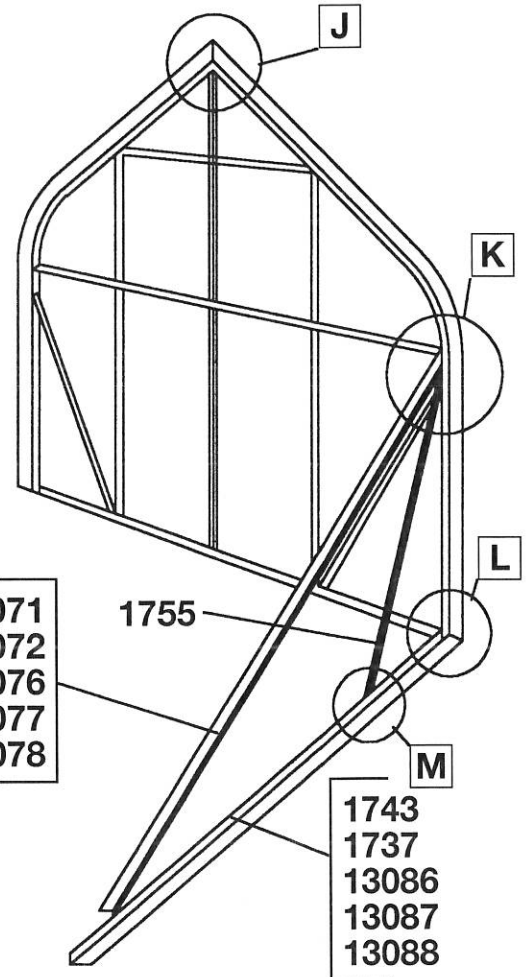
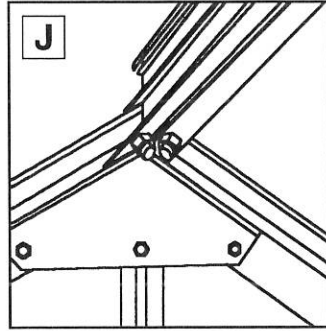
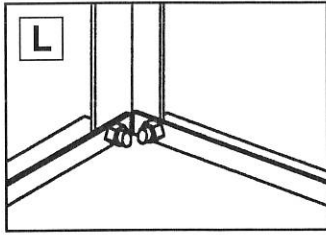
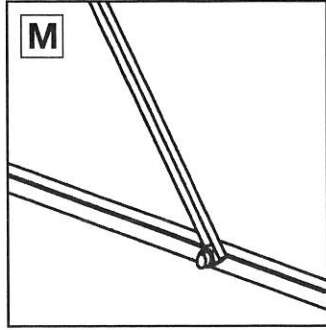
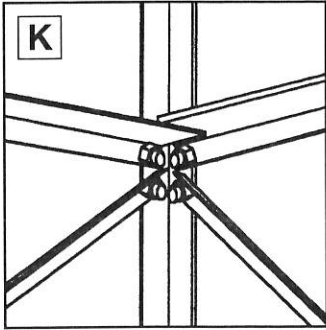

- 13071
- 13072
- 13076
- 13077
- 13078

- 1743
- 1737
- 13086
- 13087
- 13088

- 13081
- 13082
- 13083
- 13084
- 13085

- 13071
- 13072
- 13073
- 13074
- 13075

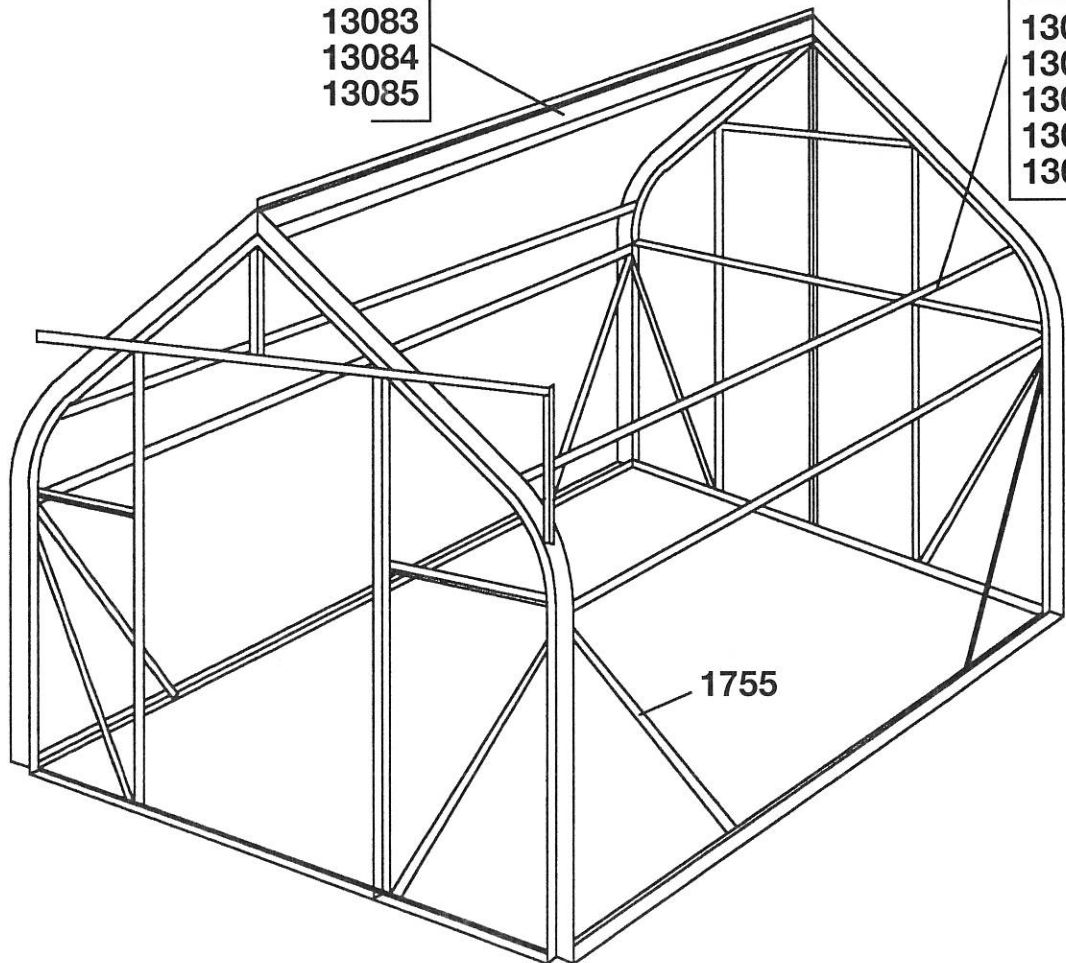

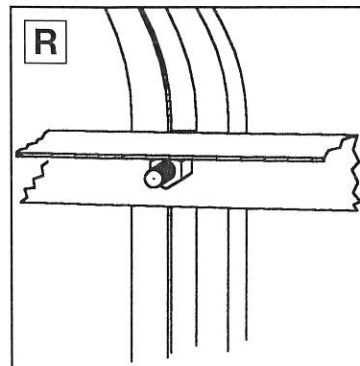
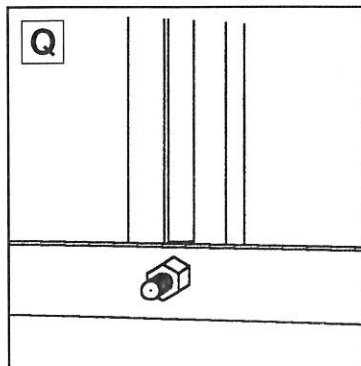
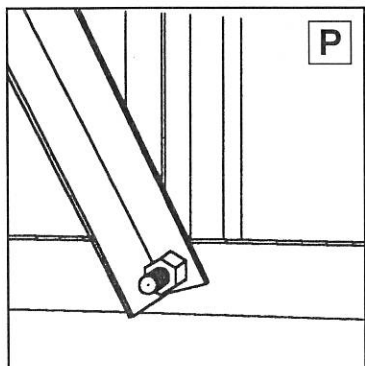
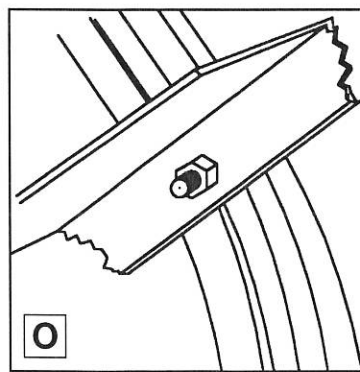
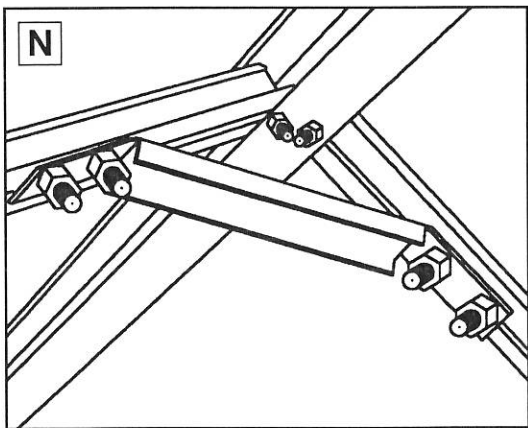
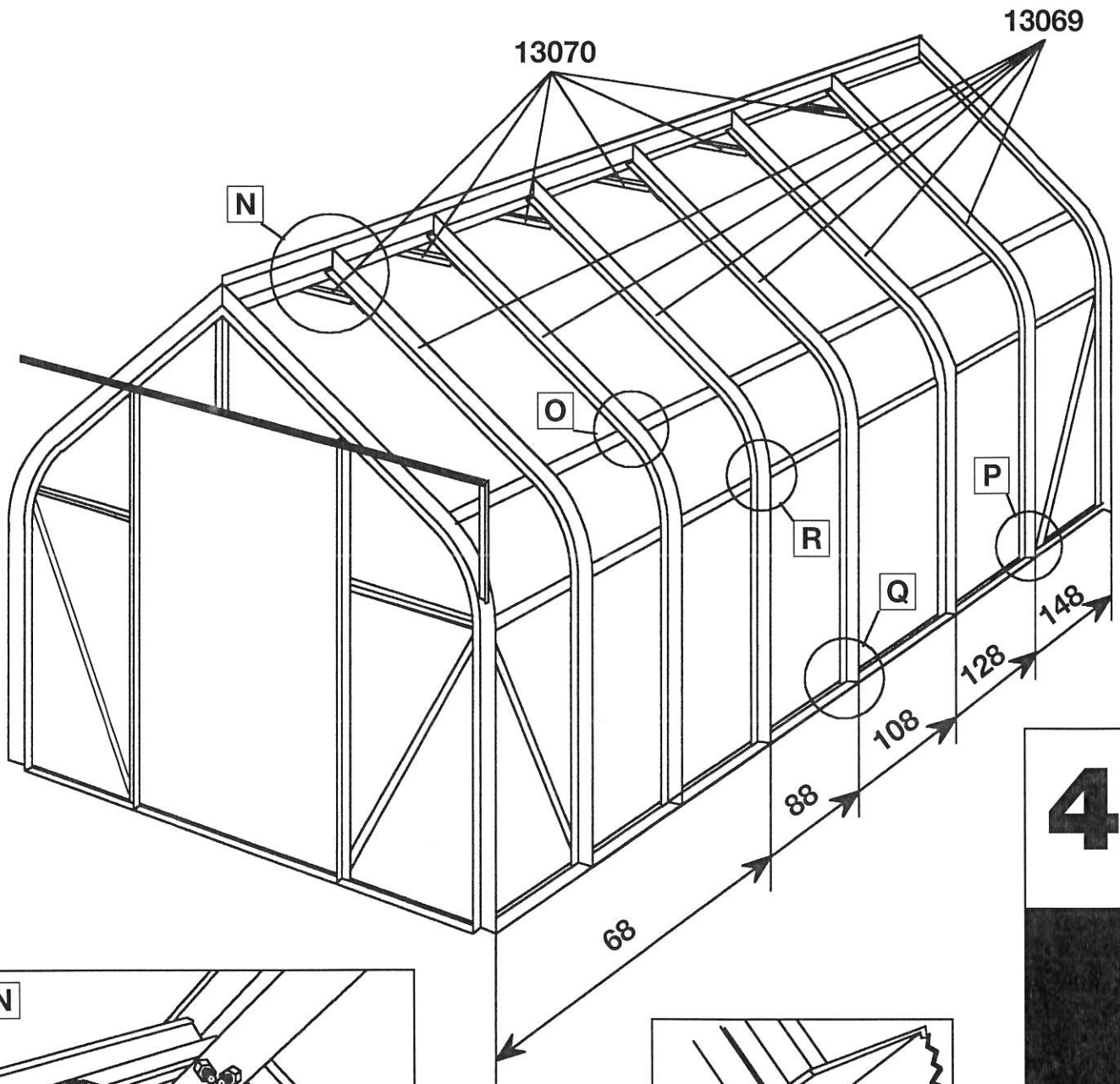

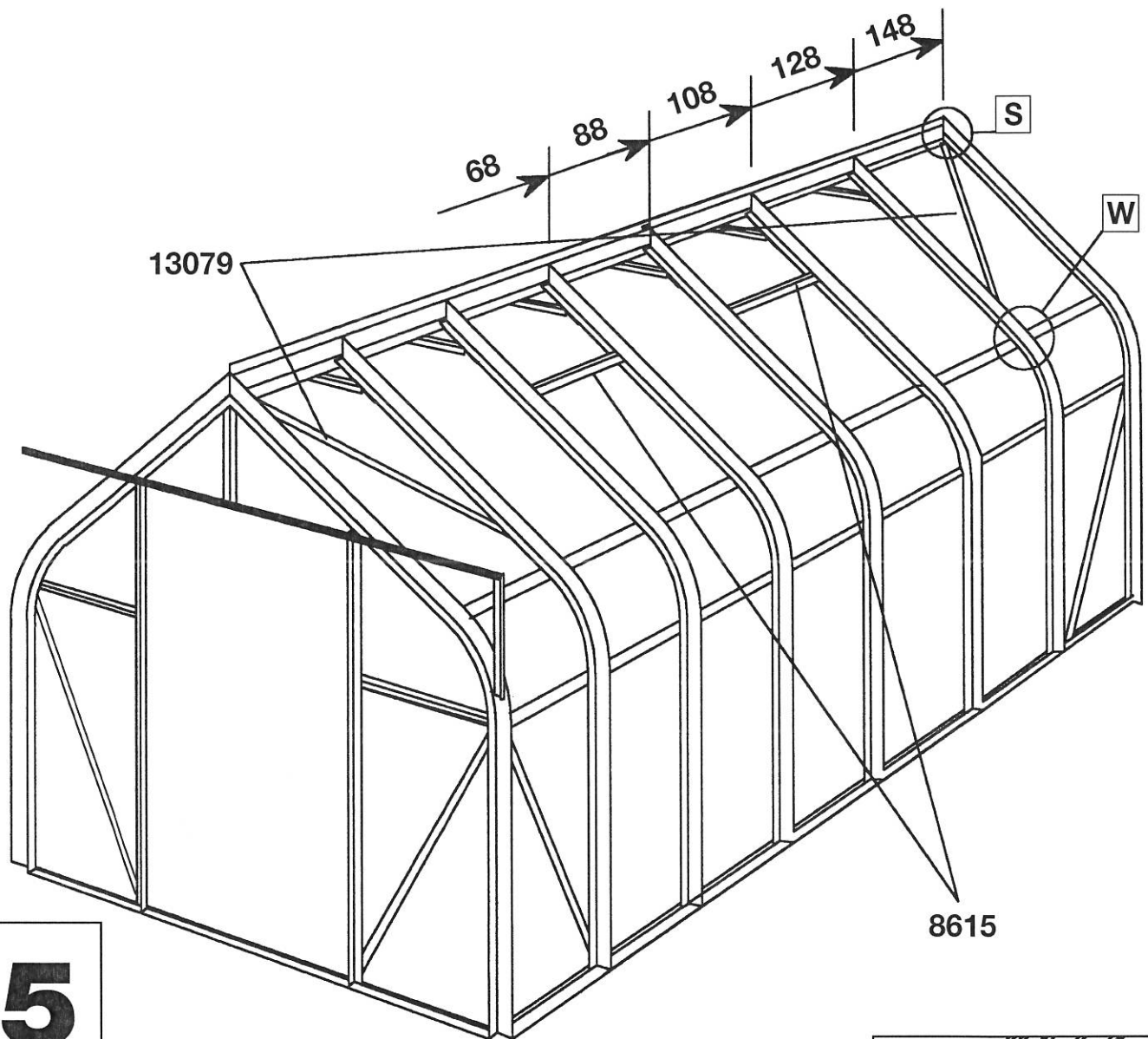

5

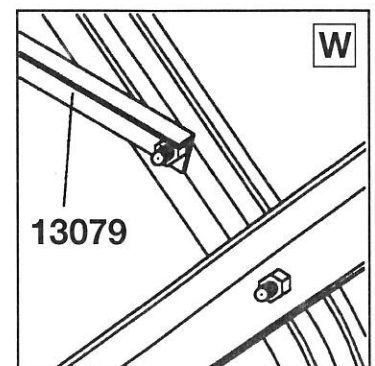
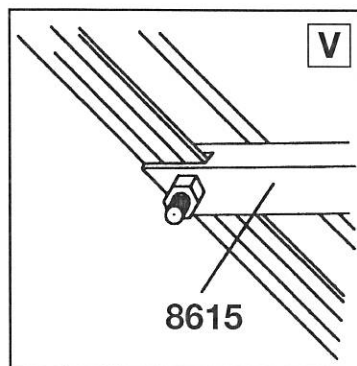
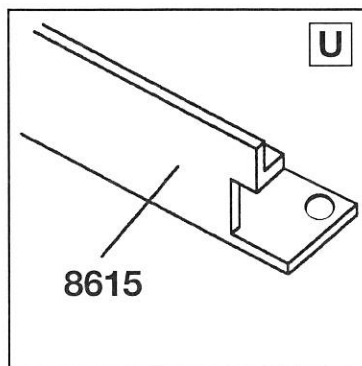
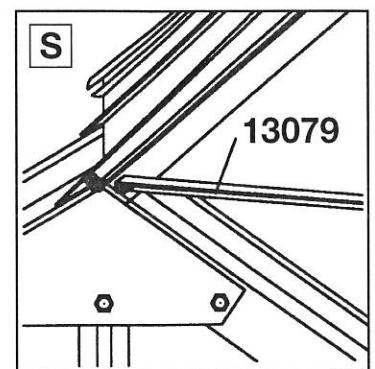

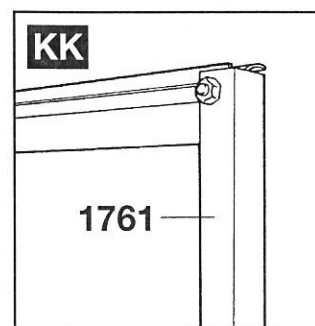
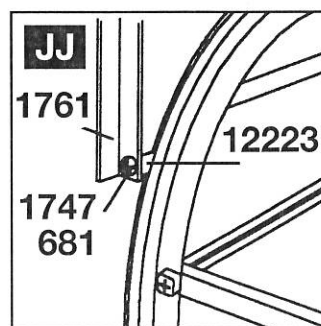
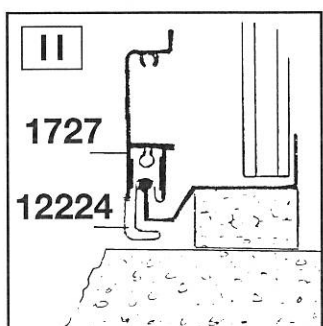
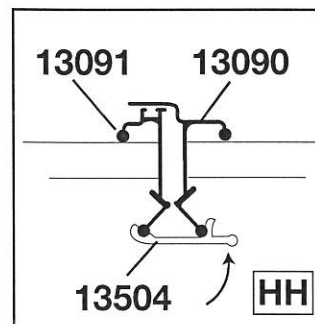
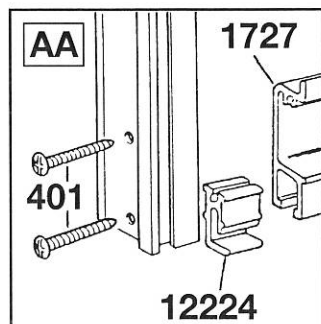
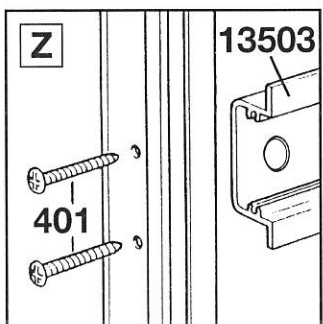
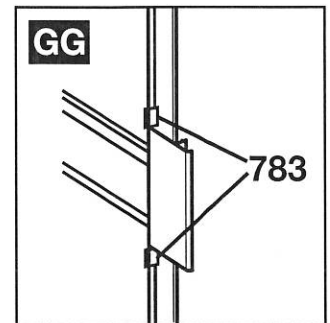
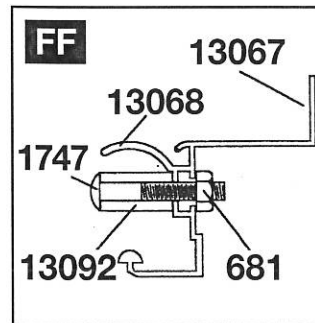
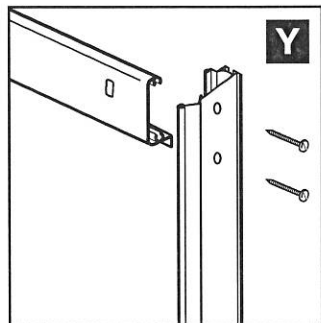
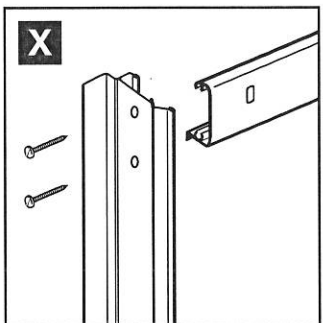
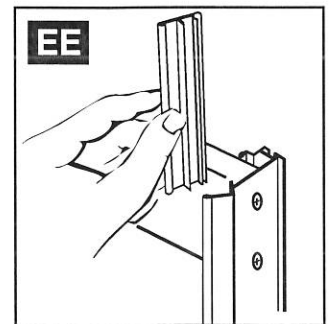
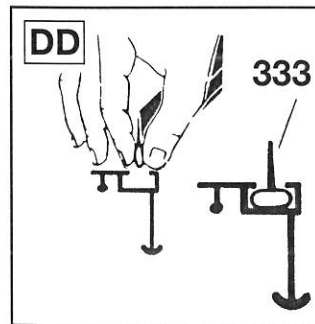
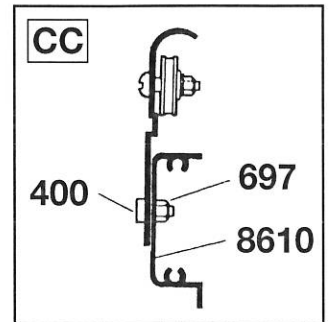
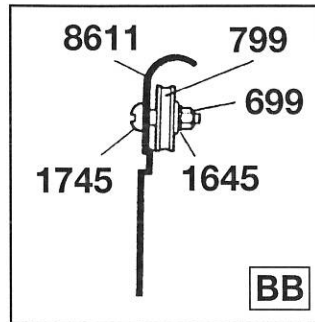
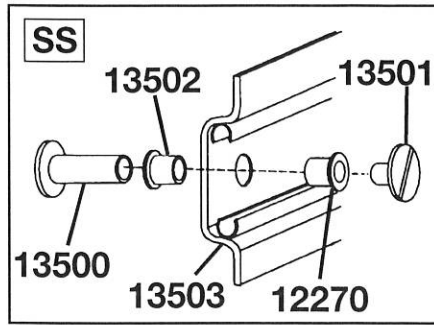
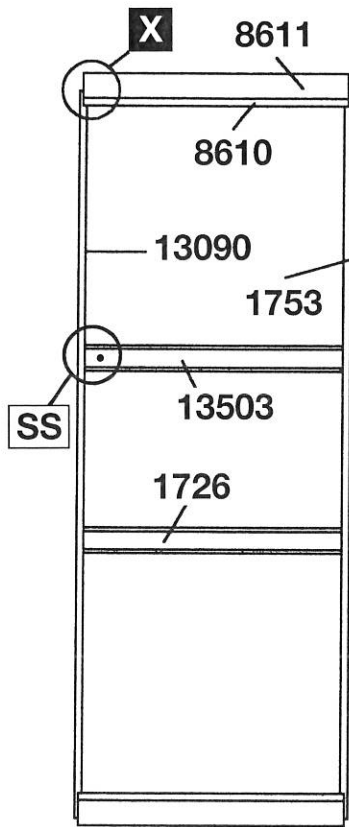
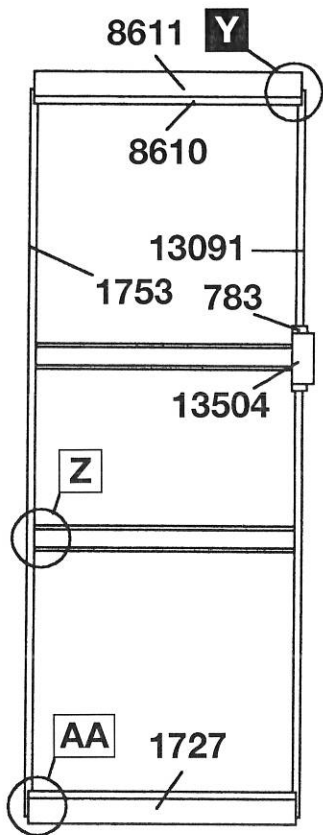

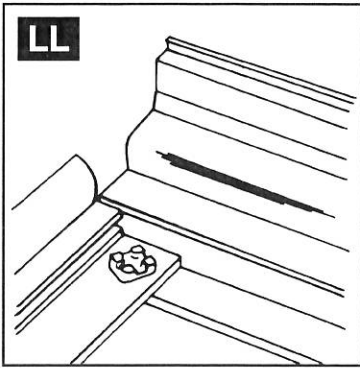

Assembly method for glazing materials up to 3.5mm thick.
 Montagemethode bei Glasstärken bis 3,5 mm.
 Schéma de montage pour vitrage jusqu'à 3.5 mm d'épaisseur.
 Assemblage methode voor beglazingsmateriaal tot 3,5 mm dikte.
 Schema di montaggio per vetri di spessore fino a 3,5 mm.

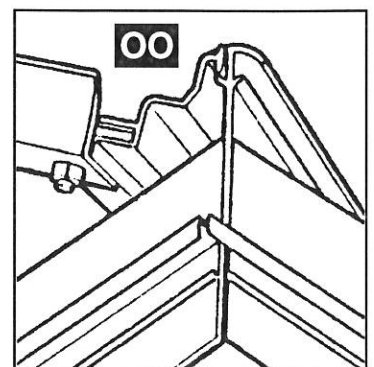
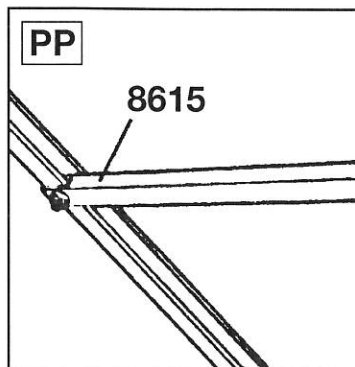
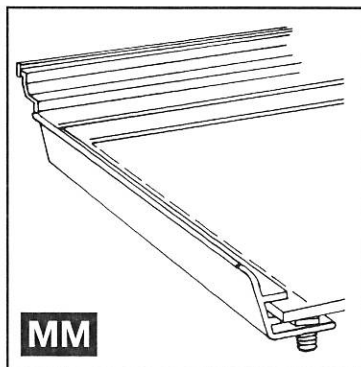
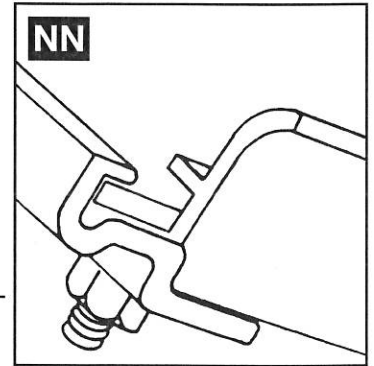
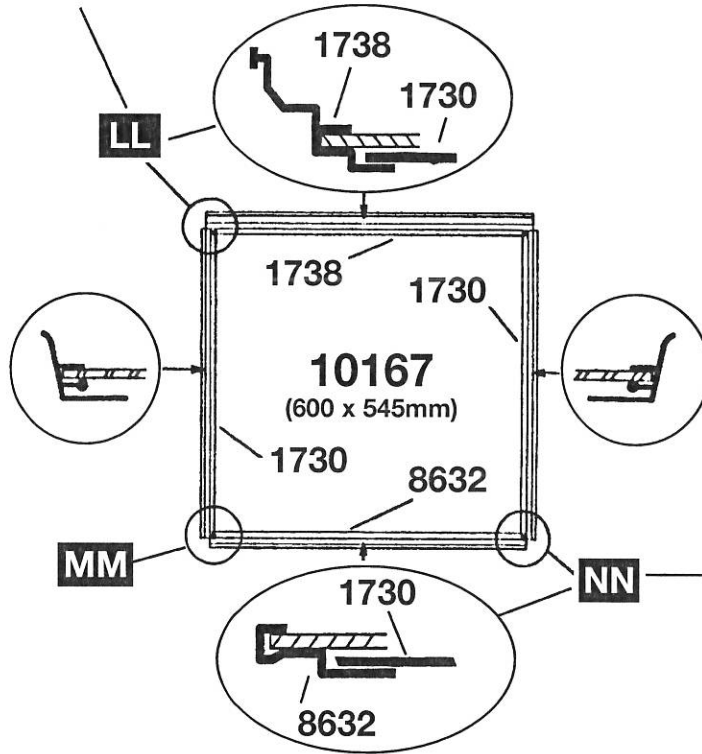

7
A

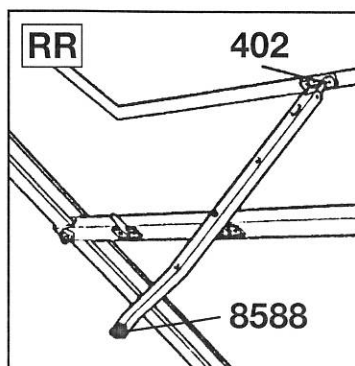
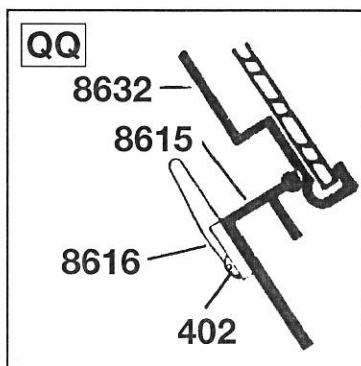

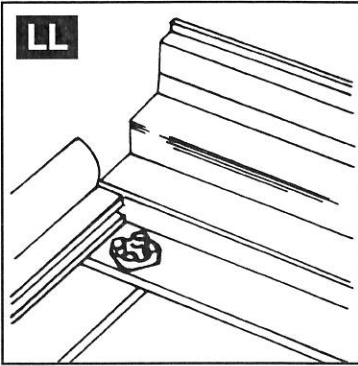

Assembly method for glazing materials from 3.5mm to 4.5mm thick.
 Montagemethode bei Glasstärken zwischen 3,5 mm und 4,5 mm.
 Schéma de montage pour vitrage de 3.5 mm à 4.5 mm d'épaisseur.
 Assemblage methode voor beglazingsmateriaal van 3,5 tot 4,5 mm dikte.
 Schema di montaggio per vetri di spessore da 3,5 mm a 4,5 mm.

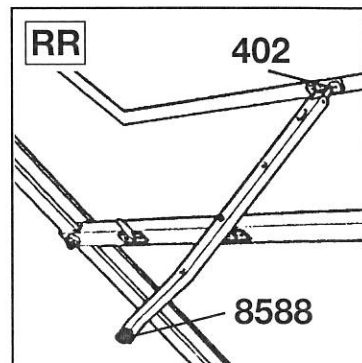
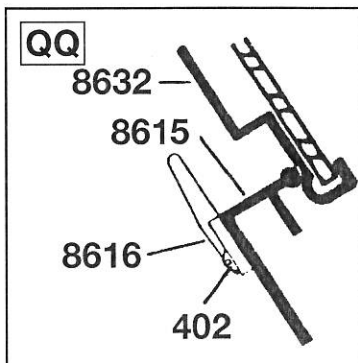
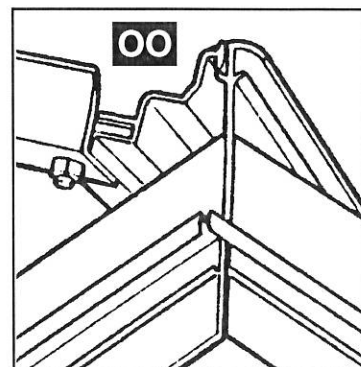
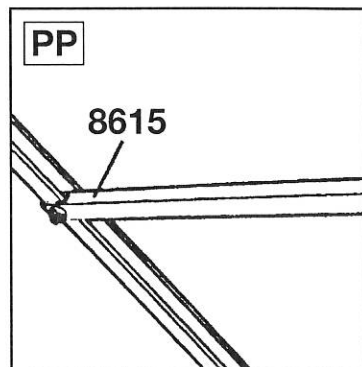
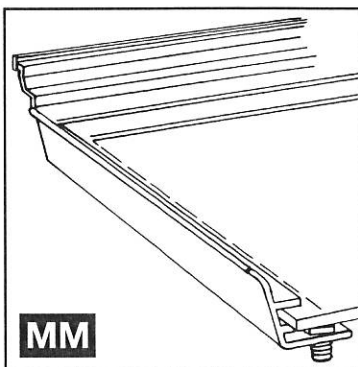
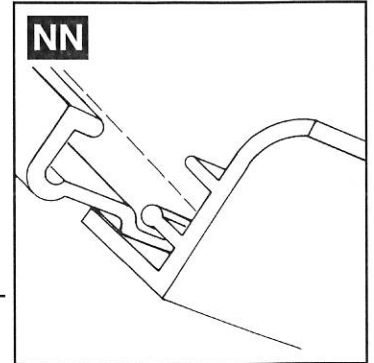
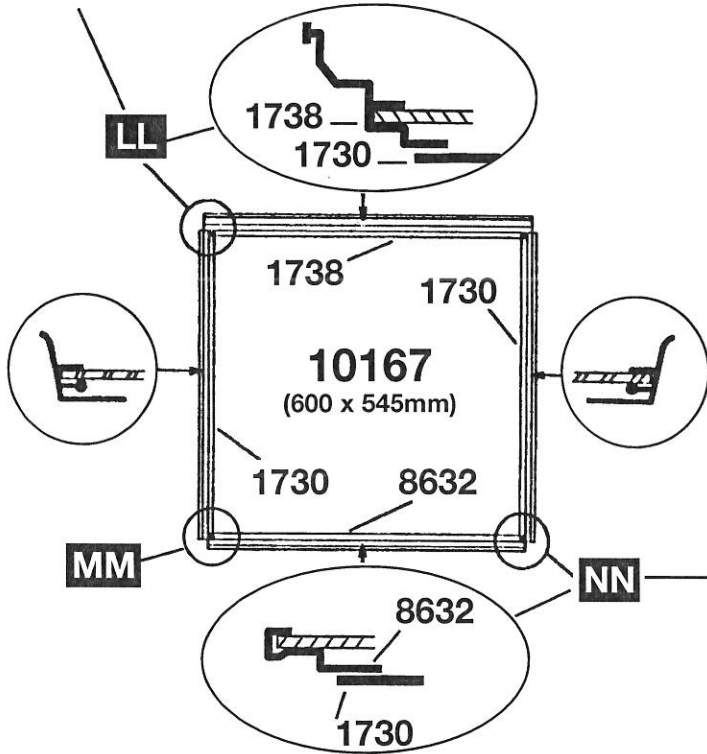

7
B

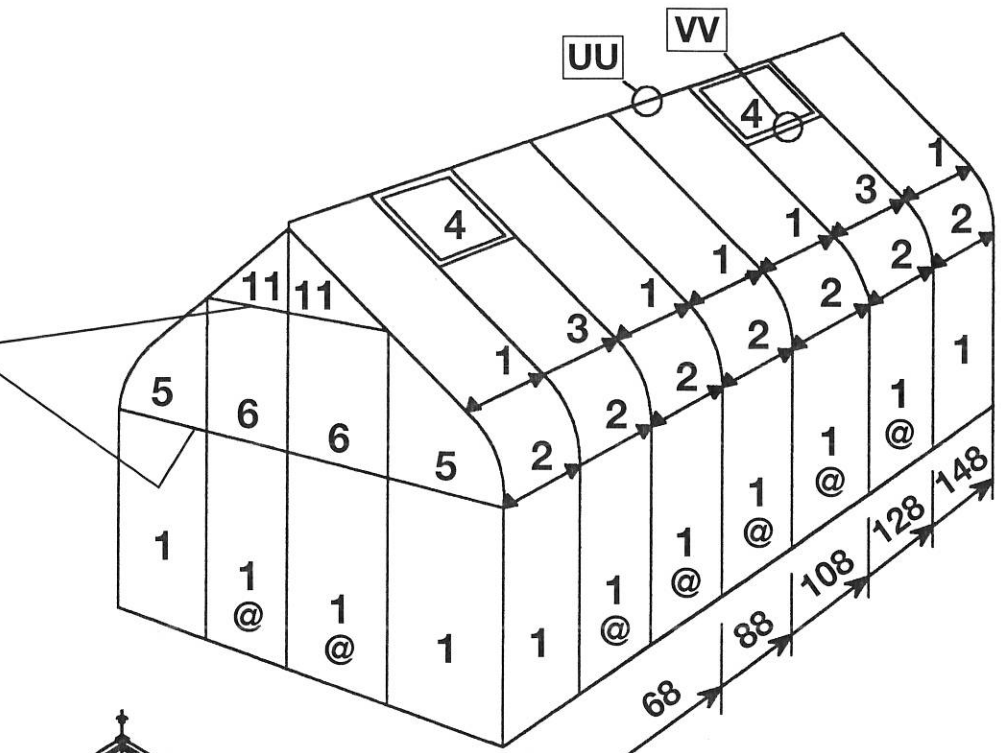
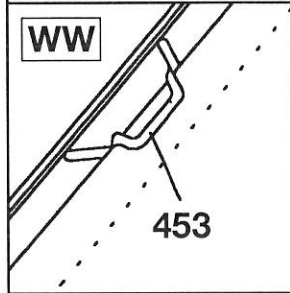
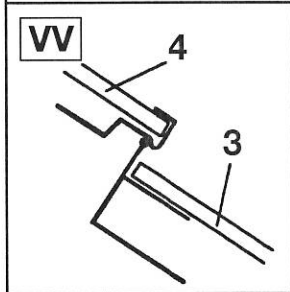
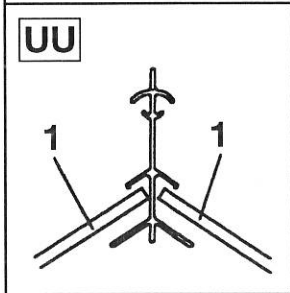
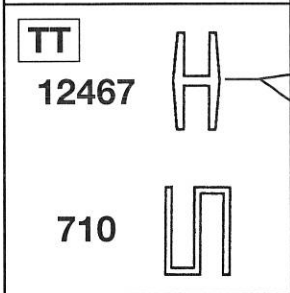
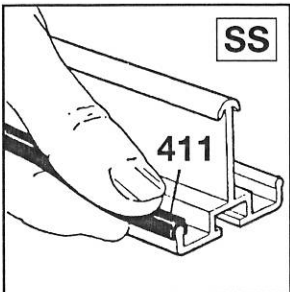

Fit one Code 453 over Code 710 as shown by
 Setzen Sie jeweils 1 Glasfederklammer (453) auf das Kunststoffprofil (710), wie in der nebenstehenden Abbildung gezeigt.
 Mettre un clips 453 au dessus de la barrette 710.
 Pas een 453 strip aan over 710 zoals getoond.
 Sæt en clips 453 over kode 710 alle steder ved 4
 Sett et klips 453 over kode 710 alle steder ved 4
 Fissare una clip codice 453 alle estremità del codice 710.

NOTE: Fit glass Nos 9 and 10 into any position marked @. This will facilitate fitting an optional louvre. Louvre replaces glass No. 9.
ACHTUNG: Montieren Sie an einer Stelle, die mit @ gekennzeichnet ist, anstelle der Scheibe Nr. 1, 2 Scheiben Nr. 10 und 1 Scheibe Nr. 9. Damit haben Sie die Möglichkeit, später an dieser Stelle 1 Lamellenfenster zu montieren. Hierbei ersetzt das Lamellenfenster die die Scheibe Nr. 9.
NOTE: Pour poser un aérateur latéral (jalousie en option), vous devez utiliser les verres 9 et 10 sur une des positions indiquée @. L'aérateur remplace le verre 9.
N.B. breng glas nrs. 9 en 10 op de @ gemerkte positie aan. Dit i.v.m. een optioneel louverraam. Het louverraam vervangt glas nr. 9.
NB! Glas nr. 9 og 10 passer i alle felter markeret @. Dette betyder, at man kan anbringe et jalousi-vindue i hvilket som helst af felterne. Jalousivinduer erstatter glas nr. 9.
NB! Glass nr. 9 og 10 passer i alle felt markert @. Dette betyr at man kan sette inn et jalousivindu i hvilket som helst av feltene. Jalousivinduer erstatter glass nr. 9.
NOTA: Montare i vetri codificati con il 9 ed il 10 in una qualsiasi delle posizioni marcate con @. Permetterà di sostituire il vetro 9 con una presa d'aria Louvre.

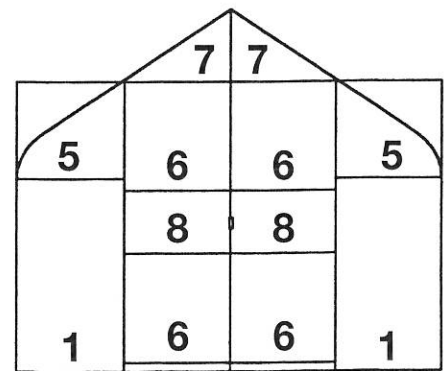

	Size mm	Material	NO OF PIECES FOR					Qty 453 Per Pce
			68	88	108	128	148	
1	610 x 1105	Glass	16	19	23	25	29	10
2	610 x 604	Plastic	6	8	10	12	14	8
3	610 x 567	Glass	1	2	2	4	4	6
4	600 x 544	Glass	1	2	2	4	4	Nil
5	610 x 620	Glass	4	4	4	4	4	4
6	610 x 610	Glass	6	6	6	6	6	4
7	610 x 415/19	Glass	2	2	2	2	2	4
8	610 x 300	Glass	2	2	2	2	2	2
9	610 x 445	Glass	1	1	1	1	1	4
10	610 x 330	Glass	2	2	2	2	2	4
11	610x 422/26	Glass	2	2	2	2	2	4

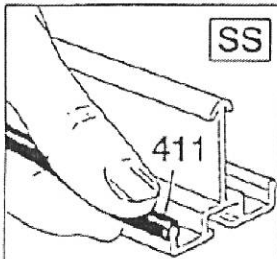

SS

Fit one Code 453 over Code 710 as shown by
 Setzen Sie jeweils 1 Glasfederklammer (453) auf das Kunststoffprofil
 (710), wie in der nebenstehenden Abbildung gezeigt.
 Mettre un clips 453 au dessus de la barrette 710.
 Pas een 453 strip aan over 710 zoals getoond.
 Sæt en klips 453 over kode 710 alle steder ved 4
 Sett et klips 453 over kode 710 alle steder ved 4
 Fissare una clip codice 453 alle estremità del codice 710.

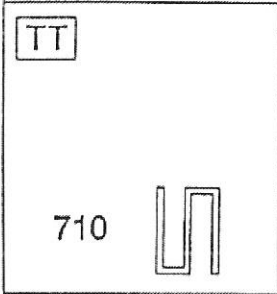

TT

710

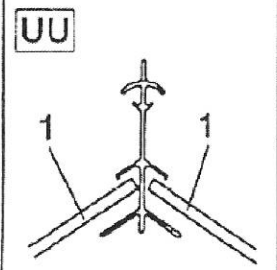

UU

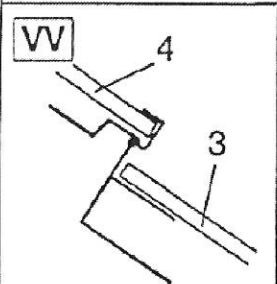

VV

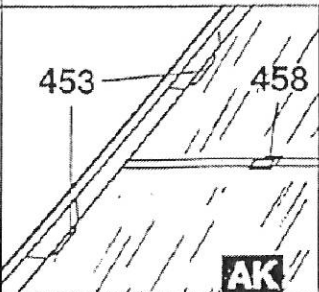

AK

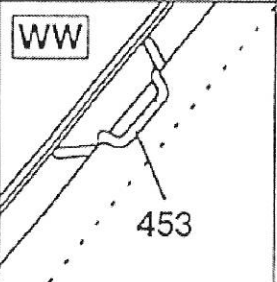
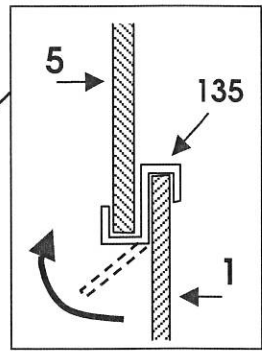
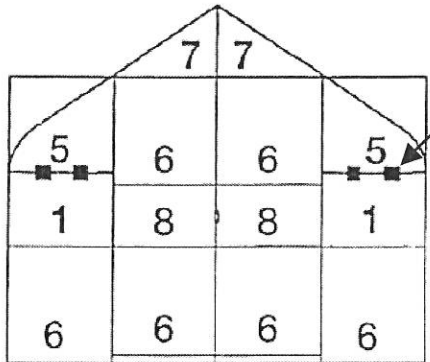

WW

453

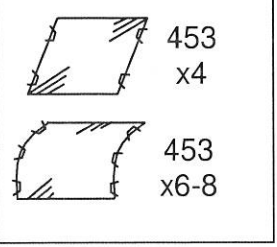

		5,0	6,7	8,3	9,9	11,5
	mm	68	88	108	128	148
1	610 x 544	11	12	14	14	16
2	610 x 604	6	8	10	12	14
3	610 x 567	6	8	10	12	14
4	600 x 544	1	2	2	4	4
5	610 x 606	4	4	4	4	4
6	610 x 610	18	20	22	24	26
7	610 x 417 x 21	4	4	4	4	4
8	610 x 300	2	2	2	2	2
9	610 x 508	6	8	10	12	14
□	458	70	70	70	70	70
■	135 (AK)					

(Plastic)

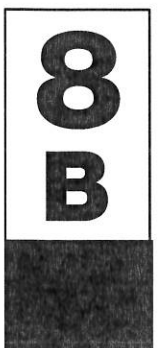

Customer Advisory Service

The utmost care has been taken in the manufacture of this quality product to ensure that it gives complete satisfaction. To the best of our knowledge the contents were complete when dispatched.

If for any reason an error has occurred in respect of shortage or damage in transit, please complete **Section B**. If you require specific advice on assembling the product please state the nature of your difficulty in **Section C**. Please complete **Section A** in all cases.

N.B. We cannot be held responsible for delays incurred in dealing with your problems through third parties. Therefore it is to your advantage to return the completed form to:

Customer Service Department, P.O. Box 947, Aylesford, Kent ME20 7RT, England.

Tel: (01622) 791234

WE RESERVE THE RIGHT TO DISALLOW CLAIMS FOR SHORTAGES OR DAMAGE UNLESS NOTIFIED TO US ON THIS FORM WITHIN SEVEN DAYS OF DELIVERY OF YOUR PRODUCT.

Our policy is one of continuous improvement and we reserve the right to change the specification without prior notice.

PLEASE USE BLOCK CAPITALS THROUGHOUT

SECTION A (Please complete in all cases)

- 1 Name
- 2 Address
- 3 Telephone Number
- 4 Date
- 5 Details of Product Purchased

Type

-
- 6 Name and address of outlet from whom purchased
 - 7 Date of purchase
 - 8 Quality Control Number

SECTION B CLAIMS FOR SHORTAGE, DAMAGE etc.

Part Description	Shortage (State Quantity)	Damaged (State Quantity)	Other (Please detail)

SECTION C ADVISORY SERVICE

Please detail nature of advice required